

## ROTÂMETROS PARA PURGA COM VÁLVULA DE PRESSÃO DIFERENCIAL - LÍQUIDOS E GASES SÉRIE KDF-9/KDG-9

KDF-9/KDG-9

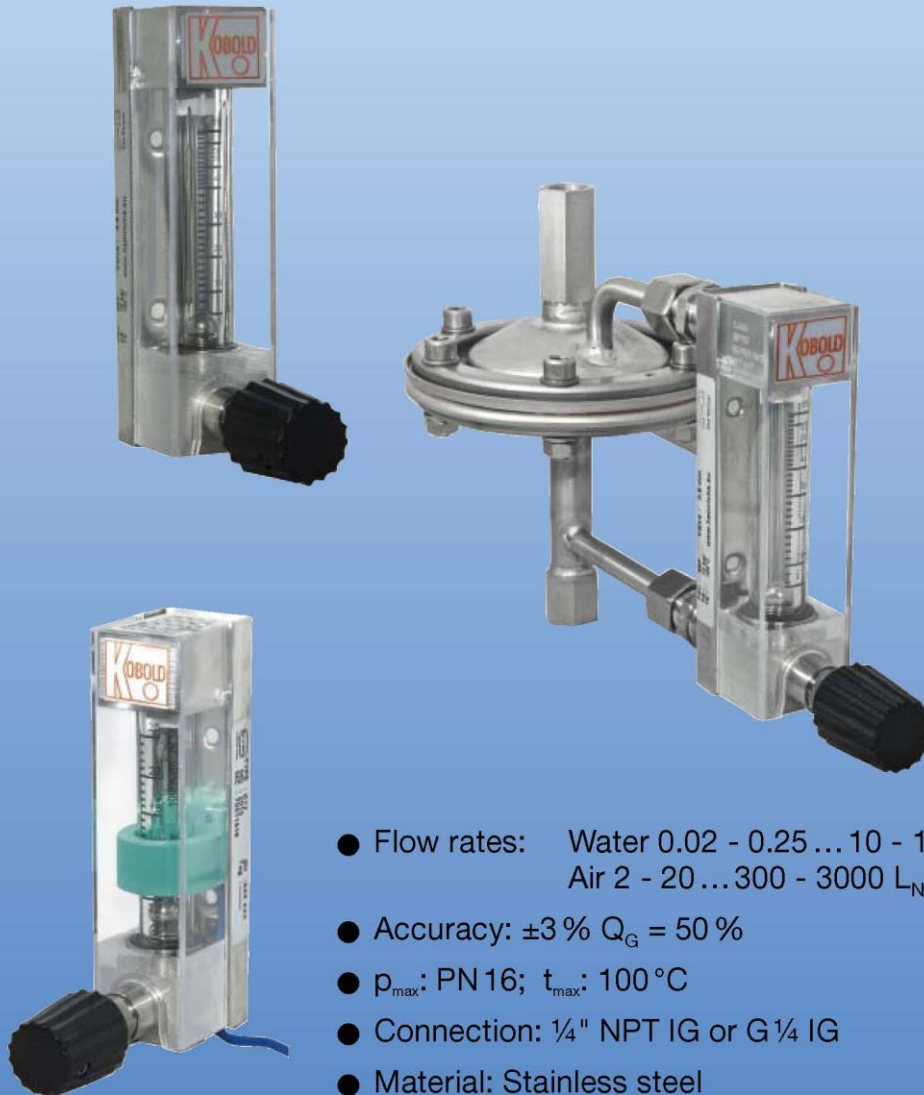

- Flow rates: Water 0.02 - 0.25 ... 10 - 100 L/h  
Air 2 - 20 ... 300 - 3000 L<sub>N</sub>/h
- Accuracy:  $\pm 3\%$   $Q_G = 50\%$
- $p_{max}$ : PN16;  $t_{max}$ : 100 °C
- Connection: 1/4" NPT IG or G 1/4 IG
- Material: Stainless steel
- Short installation length: 90 mm



**Method of operation**

The flow meters and switches for very low flows model KDF9 and KDG-9 for liquids and air operate on the suspended float principle: that is, the installation position is vertical and the direction of flow is from bottom to top. The instruments have been designed as simple and thus economical measuring systems. The float is a ball, whereby the indication point is the upper edge of the ball. A needle valve is fitted as standard.

**Areas of Application  
KDF- and KDG versions**

KDF-9... for liquids  
KDG-9... for gases

**Technical Details**

Installation position:	vertical, flow from bottom
Accuracy:	±3% Q <sub>c</sub> 50 ±3,5% of full scale (upstream pressure controller) ±5% of full scale (downstream pressure controller) (within 10-100% of measuring range) acc. VDE/VDI 3515 page 2
Max. pressure:	PN16
Process temperature:	-20 °C ... +100 °C -20 °C ... +70 °C with contact
Ambient temperature:	-20 °C ... +100 °C -20 °C ... +70 °C with contact
Protection type:	IP65 (EN60529)
Connection:	¼" NPT; G ¼" (female backward)
Option:	hose nozzle for 8 mm hose
Weight:	ca. 0.4 kg ca. 0.8 kg with controller

**Materials (in contact with the media)**

Fitting:	stainless steel 1.4404
Measuring tube:	borosilicate glass
Float stop:	Hostafion ET
Float:	stainless steel 1.4401/glass
Gasket:	FPM, option FFKM
Valve stem:	Edelstahl 1.4404
Valve seat:	PTFE 25% C (carbon fibre)
Hose nozzle:	Polyamide

**Limit switches (Option)**

The flow meters can be fitted with limit switches as an option. These limit switches are ring-type proximity switches. The electrical connection is via a 2 m cable or junction box. The electrical characteristic values for all types are according to DIN 19234 (NAMUR). Isolation switching amplifiers are necessary to operate these ring-type proximity switches (see Accessories brochure Z2).

The following types are available:

**Monostable**

Are used preferably as Min.- or Max.- contact.

**Bistable**

As limit contact used at any position of the measuring tube.

**Differential pressure controllers (Option)**

Differential pressure controllers are suitable for maintaining a constant flow rate of liquid and gaseous products in pipelines.

The differential pressure controller consists of stainless steel with an integrated membrane made of FPM or PTFE and a counterbalance valve of stainless steel.

The membrane of the controller is in balanced condition when the pressure conditions on both sides are equal. The pressure on the incoming side is determined by the medium pressure.

The pressure on the output side is determined by the pressure loss of the adjustment valve at the flow meter. During a one-sided pressure change on the incoming or output side, a pressure compensation takes place across the integrated diaphragm valve which holds the setted flow rate constant. The version to use for gases for constant upstream pressure is "valve up" and for constant downstream pressure "valve down".

For liquids the valve position is without effect on the function of measuring device.

**Important!** The controller can only regulate the pressure fluctuations of inlet or outlet. The pressure condition of the other side has to be stable

Min.- pressure difference between inlet and outlet side: 350 mbar. Max.- load of membrane at one-side load: 7 bar

Two types are available:

**Upstream pressure controller (KDF-9/KDG-9 ...E, F)**

Upstream pressure controllers hold the flow for gases and liquids constant with variable upstream pressure and constant downstream pressure.

**Downstream pressure controller (KDF-9/KDG-9...A, B)**

Downstream pressure controllers hold the flow of gaseous media constant with variable downstream pressure and constant upstream pressure.

No responsibility taken for errors; subject to change without prior notice.

Standard with needle valve



Panel mount



Downstream pressure controller



Liquids Order Details (Example: KDF-9291 NV 0 00 0)

Measuring range water [L/h]	Valve seat [mm]	Pressure Drop [mbar]	Order no. stainless steel	Connection	Gasket option	Wall-installation	Contact option	Miscellaneous options
0,02 - 0,25	2,8	2	KDF-9291...*	N = ¼" NPT R = G ¼ W = hose connector angular, 90°, for 8 mm hose S = hose connector, straight, for 8 mm hose Y = Special	V = FPM T = FFKM	0 = without W = with	00 = without with 2 m cable M3 = 1 monostable contact N3 = 1 bistable contact with junction box A3 = 1 monostable contact B3 = 1 bistable contact	0 = without E = upstream pres. contr., valve at output ¼" NPT, FPM A = downstream pres. contr., valve at input ¼" NPT, FPM F = upstream pres. contr., valve at output ¼" NPT, FFKM B = downstream pres. contr., valve at input ¼" NPT, FFKM Y = E. g. without valve. Please specify in writing
0,08 - 0,7	2,8	3	KDF-9292...*					
0,1 - 1,0	2,8	2	KDF-9279...					
0,25 - 2,5	2,8	3	KDF-9280...					
0,6 - 6,3	2,8	3	KDF-9281...					
1,0 - 10	2,8	5	KDF-9282...					
1,5 - 16	2,8	5	KDF-9283...					
2,5 - 25	2,8	5	KDF-9284...					
4,0 - 40	2,8	5	KDF-9285...					
5,0 - 65	2,8	6	KDF-9286...**					
10 - 100	2,8	6	KDF-9287...*					
Special range	on request	on request	KDF-92YY...					

Gases Order Details (Example: KDG-9288 NV 0 00 0)

Measuring range air*** [L/h]	Valve seat [mm]	Pressure Drop [mbar]	Order no. stainless steel	Connection	Gasket option	Wall-installation	Contact option	Miscellaneous options
2,0 - 20	2,8	1	KDG-9288...*	N = ¼" NPT R = G ¼ W = hose connector angular, 90°, for 8 mm hose S = hose connector, straight, for 8 mm hose Y = Special	V = FPM T = FFKM	0 = without W = with	00 = without with 2 m cable M3 = 1 monostable contact N3 = 1 bistable contact with junction box A3 = 1 monostable contact B3 = 1 bistable contact	0 = without E = upstream pres. contr., valve at output ¼" NPT, FPM A = downstream pres. contr., valve at input ¼" NPT, FPM F = upstream pres. contr., valve at output ¼" NPT, FFKM B = downstream pres. contr., valve at input ¼" NPT, FFKM Y = E. g. without valve. Please specify in writing
4,0 - 40	2,8	2	KDG-9289...*					
5,0 - 50	2,8	1	KDG-9270...					
10 - 100	2,8	2	KDG-9271...					
12 - 120	2,8	2	KDG-9290...*					
25 - 250	2,8	2	KDG-9272...					
30 - 350	2,8	2	KDG-9273...					
50 - 450	2,8	3	KDG-9274...					
60 - 800	2,8	3	KDG-9275...					
120 - 1200	2,8	3	KDG-9276...					
200 - 2000	2,8	3	KDG-9277...**					
300 - 3000	2,8	3	KDG-9278...*					
Special range	on request	on request	KDG-92YY...					

\* not available with contact  
 \*\* only available for contacts with limited switching range  
 \*\*\* at 1.2 bar absolute and 20 °C

No responsibility taken for errors; subject to change without prior notice.

## Dimensions

Standard with needle valve

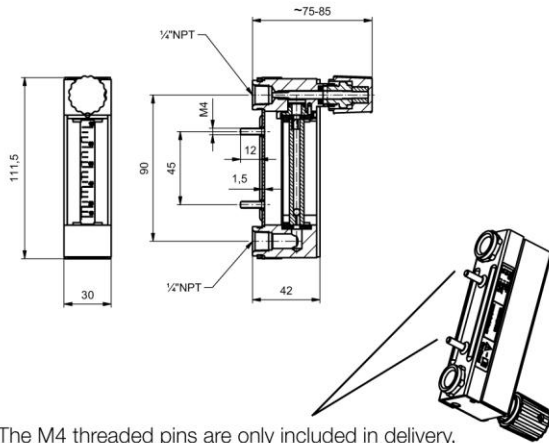

The M4 threaded pins are only included in delivery, if "wall installation" was chosen.

with contacts and junction box

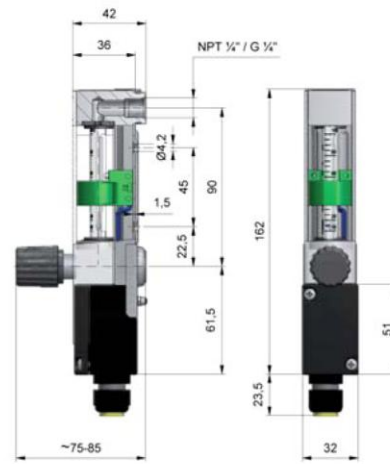

with upstream pressure controller

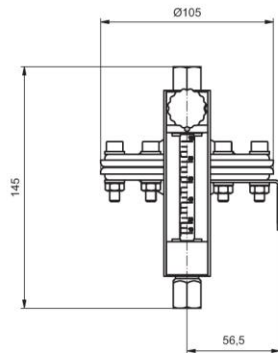

with downstream pressure controller

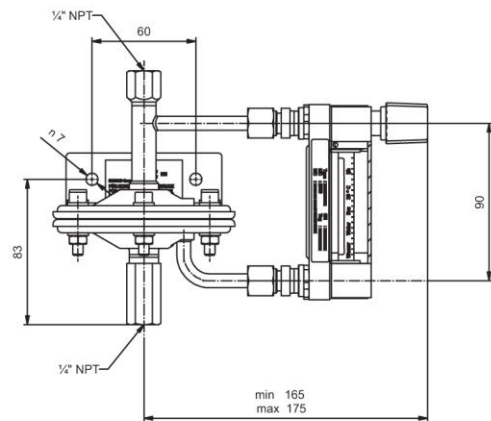
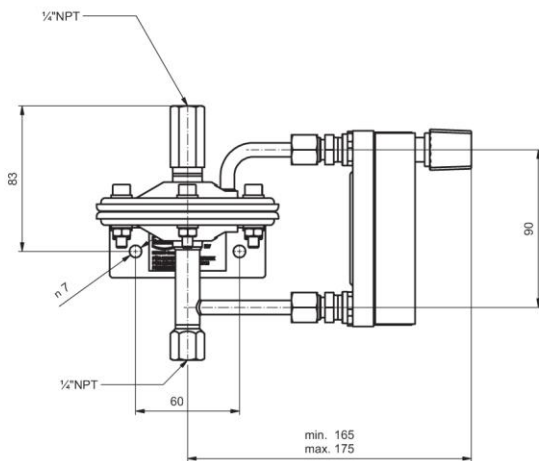
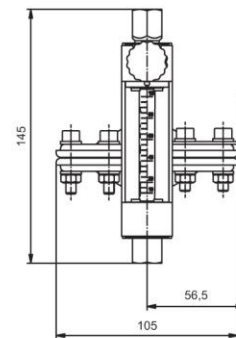

No responsibility taken for errors; subject to change without prior notice.